

ΥΠΟΥΡΓΕΙΟ ΠΑΙΔΕΙΑΣ, ΠΟΛΙΤΙΣΜΟΥ, ΑΘΛΗΤΙΣΜΟΥ ΚΑΙ ΝΕΟΛΑΙΑΣ
ΔΙΕΥΘΥΝΣΗ ΜΕΣΗΣ ΓΕΝΙΚΗΣ ΕΚΠΑΙΔΕΥΣΗΣ

ΕΝΙΑΙΑ ΓΡΑΠΤΗ ΑΞΙΟΛΟΓΗΣΗ Α΄ ΤΕΤΡΑΜΗΝΟΥ 2021-22
Γ΄ ΤΑΞΗΣ ΛΥΚΕΙΟΥ
ΗΜΕΡΟΜΗΝΙΑ: ΤΕΤΑΡΤΗ 19 ΙΑΝΟΥΑΡΙΟΥ 2022
ΕΞΕΤΑΖΟΜΕΝΟ ΜΑΘΗΜΑ: ΔΙΚΤΥΑ – CISCO (Α΄ ΣΕΙΡΑ)

ΚΩΔΙΚΟΣ ΜΑΘΗΜΑΤΟΣ: Γ060

ΟΔΗΓΟΣ ΔΙΟΡΘΩΣΗΣ / ΠΡΟΤΕΙΝΟΜΕΝΕΣ ΛΥΣΕΙΣ

ΣΥΝΟΛΙΚΗ ΔΙΑΡΚΕΙΑ ΓΡΑΠΤΗΣ ΕΞΕΤΑΣΗΣ ΔΙΚΤΥΩΝ - CISCO: 90 λεπτά

ΤΟ ΕΞΕΤΑΣΤΙΚΟ ΔΟΚΙΜΙΟ ΑΠΟΤΕΛΕΙΤΑΙ ΑΠΟ ΔΕΚΑΤΡΕΙΣ (13) ΣΕΛΙΔΕΣ

ΟΔΗΓΙΕΣ (για τους εξεταζόμενους)

1. Στο εξώφυλλο του τετραδίου απαντήσεων να συμπληρώσετε όλα τα κενά με τα στοιχεία που ζητούνται.
2. **Να απαντήσετε ΟΛΑ τα ερωτήματα.**
3. **Να μην αντιγράψετε τα θέματα** στο τετράδιο απαντήσεων.
4. Να μη γράψετε πουθενά στις απαντήσεις σας το όνομά σας.
5. Να απαντήσετε στο τετράδιό σας σε όλα τα θέματα **μόνο με μπλε πένα ανεξίτηλης μελάνης**. Μολύβι επιτρέπεται, μόνο αν το ζητάει η εκφώνηση, και μόνο για σχήματα, πίνακες, διαγράμματα κ.λπ.
6. Απαγορεύεται η χρήση διορθωτικού υγρού ή διορθωτικής ταινίας.
7. Επιτρέπεται η χρήση μη προγραμματιζόμενης υπολογιστικής μηχανής που φέρει τη σφραγίδα του σχολείου.

ΣΑΣ ΕΥΧΟΜΑΣΤΕ ΚΑΛΗ ΕΠΙΤΥΧΙΑ

ΜΕΡΟΣ Α. (30 μονάδες)

Να απαντήσετε και στις είκοσι (20) ερωτήσεις πολλαπλής επιλογής. Υπάρχει μόνο μια σωστή απάντηση σε κάθε ερώτηση. Η κάθε ερώτηση βαθμολογείται με 1½ μονάδα.

Ερώτηση 1. (Chapter 1) 2022 A

Which prompt is displayed when a network administrator successfully accesses the boot loader on a switch to recover from a system crash?

- (a) system#
- (b) switch>
- (c) switch#
- (d) **switch:**

Ερώτηση 2. (Chapter 1) 2022 A

After which step of the switch bootup sequence is the boot loader executed?

- (a) after CPU initialization
- (b) after IOS localization
- (c) **after POST execution**
- (d) after flash file system initialization

Ερώτηση 3. (Chapter 2) 2022 A

How can a network administrator reduce the number of devices that receive broadcast traffic?

- (a) Add more switches so that fewer devices are on a particular switch.
- (b) Replace the switches with switches that have more ports per switch. This will allow more devices on a particular switch.
- (c) **Segment the LAN into smaller LANs and route between them.**
- (d) Replace at least half of the switches with hubs to reduce the size of the broadcast domain.

Ερώτηση 4. (Chapter 3) 2022 A

Which type of VLAN is used to designate which traffic is untagged when crossing a trunk port?

- (a) data
- (b) default
- (c) **native**
- (d) management

Ερώτηση 5. (Chapter 3) 2022 A

A network contains multiple VLANs spanning multiple switches. What happens when a device in VLAN 30 sends a broadcast Ethernet frame?

- (a) All devices in all VLANs see the frame.
- (b) Devices in VLAN 30 and the management VLAN see the frame.
- (c) **Only devices in VLAN 30 see the frame.**
- (d) Only devices that are connected to the local switch see the frame.

Ερώτηση 6. (Chapter 2) 2022 A

Refer to the exhibit. How many broadcast domains are displayed?

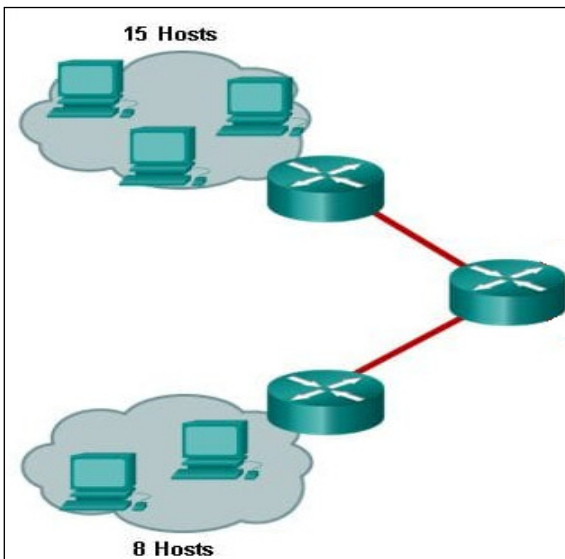

- (a) 4
- (b) 8
- (c) 23
- (d) 25

Ερώτηση 7. (Chapter 4) 2022 A

What is a disadvantage of using multilayer switches for inter-VLAN routing?

- (a) Multilayer switches are more expensive than router-on-a-stick implementations.
- (b) Multilayer switches have higher latency for Layer 3 routing.
- (c) Spanning tree must be disabled in order to implement routing on a multilayer switch.
- (d) Multilayer switches are limited to using trunk links for Layer 3 routing.

Ερώτηση 8. (Chapter 4) 2022 A

What is a characteristic of a routed port on a Layer 3 switch?

- (a) It supports trunking.
- (b) It is not assigned to a VLAN.
- (c) It is commonly used as a WAN link.
- (d) It cannot have an IP address assigned to it.

Ερώτηση 9. (Chapter 5) 2022 A

What is the function of STP in a scalable network?

- (a) It combines multiple switch trunk links to act as one logical link for increased bandwidth.
- (b) It disables redundant paths to remove Layer 2 loops.
- (c) It decreases the size of the failure domain to limit the impact of failures.
- (d) It protects the edge of the enterprise network from malicious activity.

Ερώτηση 10. (Chapter 5) 2022 A

Which STP port role is assigned to the switch port that has the lowest cost to reach the root bridge?

- (a) root port
- (b) non-designated port
- (c) designated port
- (d) disabled port

Ερώτηση 11. (Chapter 6) 2022 A

What EtherChannel technology does?

- (a) increases fault tolerance
- (b) removes L2 loops
- (c) decreases the size of broadcast domains
- (d) removes L3 loops

Ερώτηση 12. (Chapter 6) 2022 A

A network administrator configured an EtherChannel link with three interfaces between two switches. What is the result if one of the three interfaces is down?

- (a) The EtherChannel fails.
- (b) The remaining two interfaces continue to load balance traffic.
- (c) The remaining two interfaces become separate links between the two switches.
- (d) One interface becomes an active link for data traffic and the other becomes a backup link.

Ερώτηση 13. (Chapter 7) 2022 A

What is the reason that an Internet Service Provider (ISP) commonly assigns a DHCP address to a wireless router in a Small Office Home Office (SOHO) environment?

- (a) better connectivity
- (b) better network performance of SOHO
- (c) easy IP address management
- (d) easy configuration on ISP firewall

Ερώτηση 14. (Chapter 7. 2022) A

Which command, when issued in the interface configuration mode of a router, enables the interface to acquire an IPv4 address automatically from an ISP, when that link to the ISP is enabled?

- (a) ip dhcp pool
- (b) ip address dhcp
- (c) service dhcp
- (d) ip helper-address

Ερώτηση 15. (Chapter 8) 2022 A

Which ICMPv6 message is sent by a host in an attempt to locate an online IPv6 enabled router to obtain IPv6 addressing information?

- (a) Neighbor Advertisement (NA)
- (b) Neighbor Solicitation (NS)
- (c) Router Solicitation (RS)
- (d) Router Advertisement (RA)

Ερώτηση 16. (Chapter 8) 2022 A

What method can be used to generate an interface ID by an IPv6 host that is using SLAAC?

- (a) ARP
- (b) EUI-64
- (c) stateful DHCP v6
- (d) DAD

Ερώτηση 17. (CCNA3-Chapter 4) 2022 A

What wild card mask will match networks 172.32.0.0/16 through 172.39.0.0/16?

- (a) 0.0.255.255
- (b) 0.3.255.255
- (c) 0.7.255.255
- (d) 0.15.255.255

Ερώτηση 18. (CCNA3-Chapter 4) 2022 A

If a router has three (3) interfaces and routes only IPv4 traffic. What is the maximum number of ACLs that can be applied on it?

- (a) 2
- (b) 3
- (c) 6
- (d) 12

Ερώτηση 19. (CCNA3-Chapter 5. 2022) A

Which command will verify the number of packets that are permitted or denied by an ACL?

- (a) show running-config.
- (b) show access-lists.
- (c) show ip interface brief.
- (d) show interfaces.

Ερώτηση 20. (CCNA3-Chapter 5) 2022 A

Refer to the exhibit. A router has an existing ACL that permits all traffic from the 172.16.0.0/16 network. The administrator attempts to add a new ACE to the ACL that denies packets from host 172.16.0.1 and receives the error message that is shown in the exhibit. What action can the administrator take to block packets from host 172.16.0.1 while still permitting all other traffic from the 172.16.0.0/16 network?

```
Router(config)# access-list 1 deny 172.16.0.1
% Access rule can't be configured at higher sequence num
as it is part of the existing rule at sequence num 10
Router(config)# exit
Router# show access-lists 1
Standard IP access list 1
 10 permit 172.16.0.0, wildcard bits 0.0.255.255
```

- (a) Manually add the new deny ACE with a sequence number of 5.
- (b) Manually add the new deny ACE with a sequence number of 15.
- (c) Create a second access list denying the host and apply it to the same interface.
- (d) Add a deny any ACE to access-list 1.

Μέρος Β (30 μονάδες)
 Να απαντήσετε σε όλες τις ερωτήσεις. Η κάθε ερώτηση βαθμολογείται με έξι (6) μονάδες.

Ερώτηση 1. (CCNA2 - Chapter 5) 2022 A

The following network topology is given. Fill in the below tables by specifying which switch will play the role of **Root Bridge** and the STP role of each port (**DP**=Designated Port, **RP**=Root Port, **AP/B**=Alternate Port/Blocked).

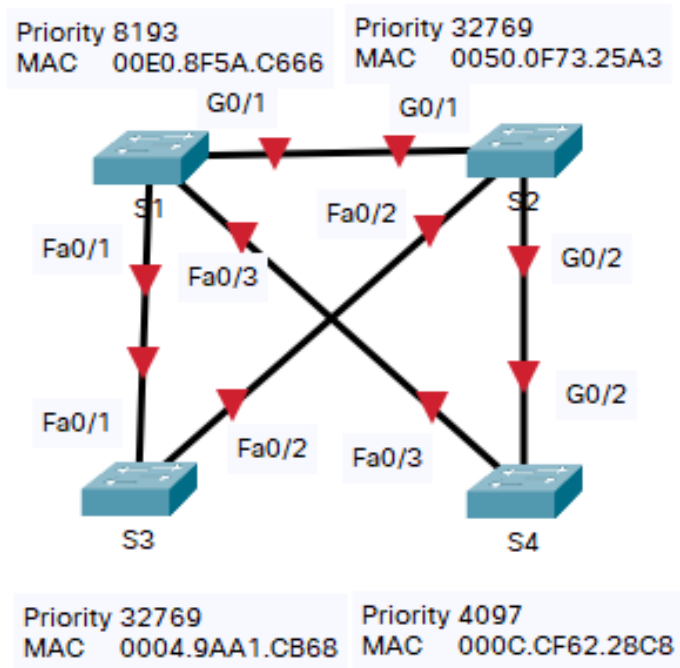

Root Bridge Switch	S4
---------------------------	-----------

(1 pt)

Switch	Port	Role	Switch	Port	Role
S1	Fa0/1	DP	S2	G0/2	RP
S1	Fa0/3	AP/B	S3	Fa0/1	AP/B
S1	G0/1	RP	S3	Fa0/2	RP
S2	Fa0/2	DP	S4	Fa0/3	DP
S2	G0/1	DP	S4	G0/2	DP

(5 pts)

Ερώτηση 2. (CCNA2 - Chapter 7) 2022 A

The figure below shows the DHCPv4 communication for obtaining a lease. Fill up the boxes by specifying the DHCPv4 message type (4 pts) and whether the message is a unicast or broadcast (2 pts).

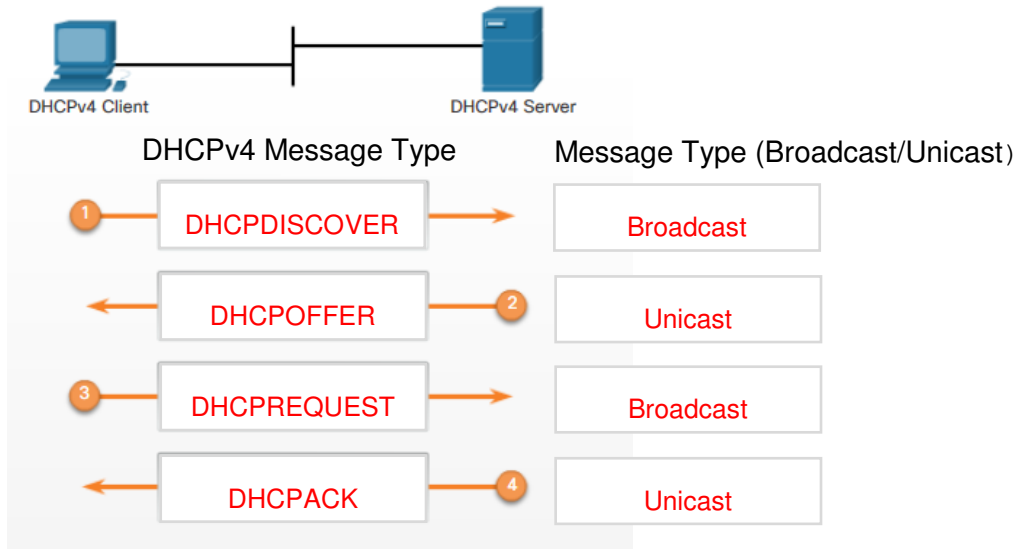

Ερώτηση 3. (Chapter 1.1.6 Switch SVI Configuration) 2022 A

The tasks below are required to configure the management interface of a switch with the following details:

- IPv4 address: 192.168.10.20
- Subnet Mask: 255.255.255.0
- SVI VLAN: 99

Write the IOS command that corresponds to each task.

	Task	IOS Command
(a)	Enter global configuration mode	configure terminal
(b)	Enter interface configuration mode for the SVI.	interface vlan 99
(c)	Configure the management interface IPv4 address.	ip address 192.168.10.20 255.255.255.0
(d)	Enable the management interface.	no shutdown
(e)	Return to the privileged EXEC mode.	end (or exit, exit)
(f)	Save the running config to the startup config.	copy running-config startup-config

Ερώτηση 4. (Chapter 5 Enterprise Networking, Security, and Automation) 2022 A

For each access list entry, determine the action that will be taken (Permit or Deny) when applied to the comparison address provided:

	Access List Entry (ACE)	Comparison Address	Permit or Deny
(a)	Access-list 1 permit 192.168.222.100 0.0.0.255	192.168.100.222	Deny
(b)	Access-list 2 permit 192.168.22.22 0.0.255.255	192.168.21.21	Permit
(c)	Access-list 3 permit 192.168.22.23 0.255.255.255	192.169.21.24	Permit
(d)	Access-list 4 permit 192.168.22.128 0.0.0.127	192.168.22.127	Deny
(e)	Access-list 5 permit 192.168.22.64 0.0.0.63	192.168.23.65	Deny
(f)	Access-list 6 permit 192.168.22.32 0.0.0.31	192.168.22.64	Deny

Ερώτηση 5. (Chapter 6.1.9. 2022) A

Consider the two switches in the figure. Whether S1 and S2 establish an EtherChannel using LACP depends on the mode settings on each side of the channel:

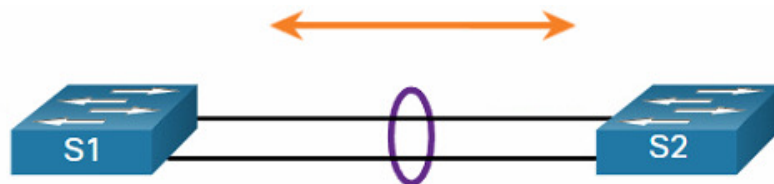

The table shows various combinations of LACP modes on S1 and S2. Fill in the Channel Establishment result for each combination.

	S1	S2	Channel Establishment (Yes / No)
(a)	On	On	Yes
(b)	On	Active/Passive	No
(c)	Active	Active	Yes
(d)	Active	Passive	Yes
(e)	Passive	Active	Yes
(f)	Passive	Passive	No

ΜΕΡΟΣ Γ (40 Μονάδες)

Να απαντήσετε σε όλες τις ερωτήσεις. Η κάθε ερώτηση βαθμολογείται με είκοσι (20) μονάδες.

Ερώτηση 1. (Chapter 4,7) 2022 A

You have been asked to configure a network with VLAN technology, inter-VLAN routing and DHCPv4 service. The topology and all relevant details are shown below. Follow the instructions to implement the solution.

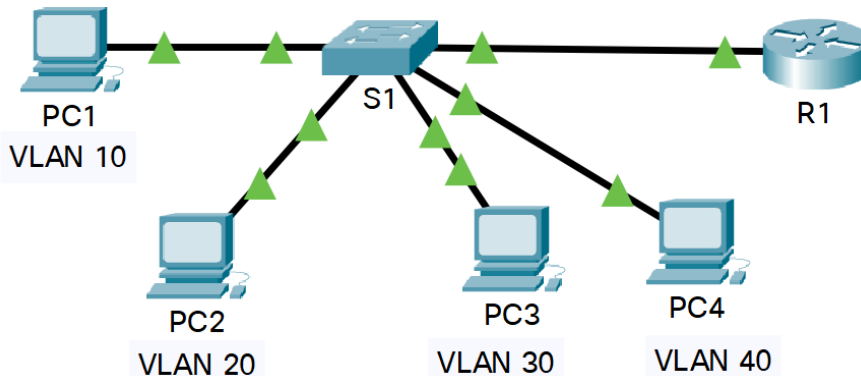
**Addressing Table**

Device	Interface	IP Address	Subnet Mask	Default Gateway
R1	G0/0.10	172.31.10.1	255.255.255.224	N/A
	G0/0.20	172.31.20.1	255.255.255.240	N/A
	G0/0.30	172.31.30.1	255.255.255.128	N/A
	G0/0.40	172.31.40.1	255.255.255.192	N/A
PC1	NIC	DHCP Assigned	DHCP Assigned	DHCP Assigned
PC2	NIC	DHCP Assigned	DHCP Assigned	DHCP Assigned
PC3	NIC	DHCP Assigned	DHCP Assigned	DHCP Assigned
PC4	NIC	DHCP Assigned	DHCP Assigned	DHCP Assigned

VLAN Port Assignments and DHCP Information

Ports	VLAN Number	VLAN Name	DHCP Pool Name	Network
Fa0/5 - Fa0/9	VLAN 10	Sales	VLAN_10	172.31.10.0/27
Fa0/10 - Fa0/14	VLAN 20	Production	VLAN_20	172.31.20.0/28
Fa0/15 - Fa0/19	VLAN 30	Marketing	VLAN_30	172.31.30.0/25
Fa0/20 - Fa0/24	VLAN 40	HR	VLAN_40	172.31.40.0/26

- (a) Create, name the VLANs and assign them to the appropriate ports on S1. Names are case-sensitive.
- (b) Configure port G0/0 on S1 for trunking.

```
S1(config)#
```

```
vlan 10
```

```
name Sales
```

```
vlan 20
```

```
name Production
```

```
vlan 30
```

```
name Marketing
```

```
vlan 40
```

```
name HR
```

```
interface range fa0/5 – 9
```

```
switchport mode access
```

```
switchport access vlan 10
```

```
interface range fa0/10 - 14
```

```
switchport mode access
```

```
switchport access vlan 20
```

```
interface range fa0/15-19
```

```
switchport mode access
```

```
switchport access vlan 30
```

```
interface range fa0/20-24
```

```
switchport mode access
```

```
switchport access vlan 40
```

```
int g0/0
```

```
switchport mode trunk (4 p. VLANs + 4 p. Assign ports to VLANs + 2 p. trunking = 10 p.)
```

- (c) Configure R1 to route between VLANs. **Subinterface names should match the VLAN number.**

```
R1(config)#
```

```
interface GigabitEthernet0/0
```

```
no shutdown
```

```
interface GigabitEthernet0/0.10
```

```
encapsulation dot1Q 10
```

```
ip address 172.31.10.1 255.255.255.224
```

```
interface GigabitEthernet0/0.20
```

```
encapsulation dot1Q 20
```

```
ip address 172.31.20.1 255.255.255.240
```

```
interface GigabitEthernet0/0.30
```

```
encapsulation dot1Q 30
```

```
ip address 172.31.30.1 255.255.255.128
```

```
interface GigabitEthernet0/0.40
```

```
encapsulation dot1Q 40
```

```
ip address 172.31.40.1 255.255.255.192
```

(4 p. subint VLANS)

- (d) Configure R1 to act as a DHCPv4 server for all the VLANs attached to S1.
- Prevent the first 10 addresses from each VLAN being assigned to end devices.
 - Create a DHCP pool for each VLAN.
 - i. Name it (case-sensitive)
 - ii. Specify the range of addresses given.
 - iii. Specify the default gateway.
 - iv. Specify the dns server as 209.165.201.14.

R1(config)#

```
ip dhcp excluded-address 172.31.10.1 172.31.10.10
ip dhcp excluded-address 172.31.20.1 172.31.20.10
ip dhcp excluded-address 172.31.30.1 172.31.30.10
ip dhcp excluded-address 172.31.40.1 172.31.40.10
```

```
ip dhcp pool VLAN_10
network 172.31.10.0 255.255.255.224
default-router 172.31.10.1
dns-server 209.165.201.14
```

```
ip dhcp pool VLAN_20
network 172.31.20.0 255.255.255.240
default-router 172.31.20.1
dns-server 209.165.201.14
```

```
ip dhcp pool VLAN_30
network 172.31.30.0 255.255.255.128
default-router 172.31.30.1
dns-server 209.165.201.14
```

```
ip dhcp pool VLAN_40
network 172.31.40.0 255.255.255.192
default-router 172.31.40.1
dns-server 209.165.201.14
```

(2 p. excluded + 4 p. pools = 6 p.)

Ερώτηση 2. (ACL Chapter 4,5) 2022 A

You have been asked to configure remote management and secure a network with standard ACLs. The topology and all relevant details are shown below. Follow the instructions to implement the solution.

Topology

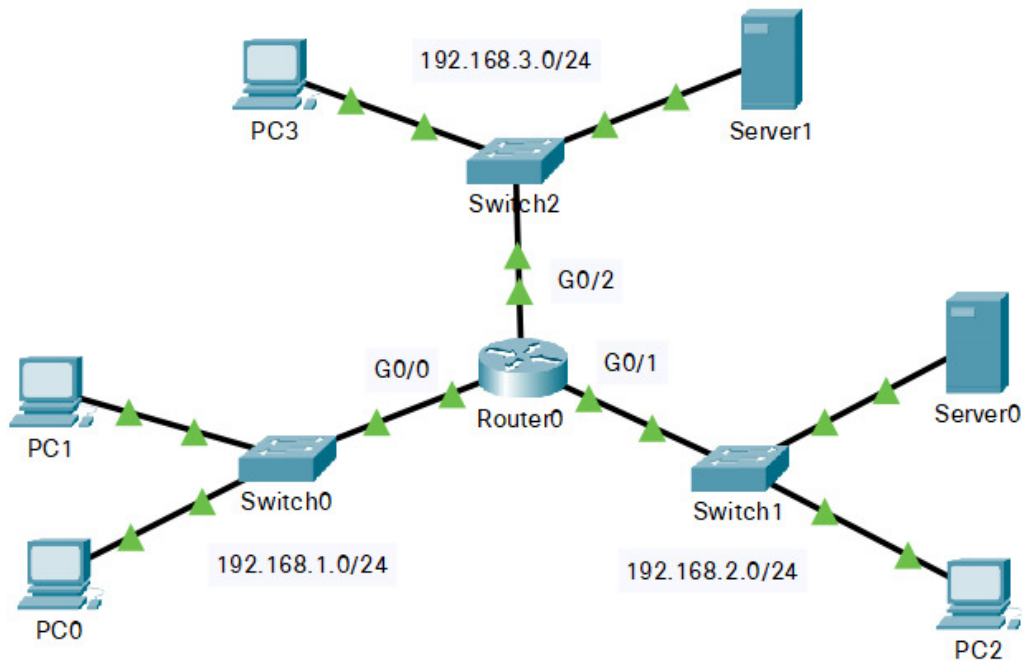

Addressing Table

Device	Interface	IP Address	Subnet Mask	Default Gateway
Router0	G0/0	192.168.1.1	255.255.255.0	N/A
	G0/1	192.168.2.1	255.255.255.0	N/A
	G0/2	192.168.3.1	255.255.255.0	N/A
PC0	NIC	192.168.1.10	255.255.255.0	192.168.1.1
PC1	NIC	192.168.1.11	255.255.255.0	192.168.1.1
PC2	NIC	192.168.2.10	255.255.255.0	192.168.2.1
PC3	NIC	192.168.3.10	255.255.255.0	192.168.3.1
Server0	NIC	192.168.2.11	255.255.255.0	192.168.2.1
Server1	NIC	192.168.3.11	255.255.255.0	192.168.3.1
Switch0	VLAN 1	192.168.1.13	255.255.255.0	192.168.1.1

(a) Configure Switch0 to be accessible for remote management from any LAN through Telnet. Specify vlan 1 as SVI, default gateway and password **Cisco22** for all vty lines. (7 pts)

```
Switch0(config)#int vlan 1
```

```
Switch0(config-if)#ip address 192.168.1.13 255.255.255.0
```

```
Switch0(config-if)#no shut
```

```
Switch0(config-if)#exit (no points)
```

```
Switch0(config)#ip default-gateway 192.168.1.1
```

```
Switch0(config)#line vty 0 15
```

```
Switch0(config-line)#password Cisco22
```

```
Switch0(config-line)#login
```

(b) Create a standard ACL 1 which will deny access to network 192.168.3.0/24 from PC0. All other traffic should be allowed access to 192.168.3.0/24 network. Place the ACL on the right interface and direction. (4 pts)

```
Router0(config)#access-list 1 deny host 192.168.1.10
```

```
Router0(config)#access-list 1 permit any
```

```
Router0(config)#int g0/2
```

```
Router0(config-if)#ip access-group 1 out
```

(c) Create a standard ACL 2 which will deny PC2 from accessing any remote network. Place the ACL on the right interface and direction. (4 pts)

```
Router0(config)#access-list 2 deny host 192.168.2.10
```

```
Router0(config)#access-list 2 permit any
```

```
Router0(config)#int g0/1
```

```
Router0(config-if)#ip access-group 2 in (or ip access-group 2 out for both G0/0 and G0/2)
```

(d) Create a standard ACL 3 which will deny Server1 and hosts from 192.168.2.0/24 network to access 192.168.1.0/24 network. All other hosts on 192.168.3.0/24 network should be permitted access. Place the ACL on the right interface and direction. (5 pts)

```
Router0(config)#access-list 3 deny host 192.168.3.11
```

```
Router0(config)#access-list 3 deny 192.168.2.0 0.0.0.255
```

```
Router0(config)#access-list 3 permit any
```

```
Router0(config)#int g0/0
```

```
Router0(config-if)#ip access-group 3 out
```

ΤΕΛΟΣ ΕΞΕΤΑΣΤΙΚΟΥ ΔΟΚΙΜΙΟΥ